

HERKULES
FITNESS EN PLEIN AIR



W
U
G
O
L
T
A
C



**FR**

Nous sommes convaincus que l'activité physique est essentielle à la santé et au bien-être mental ainsi qu'aux interactions sociales. Surtout aujourd'hui, il est de plus en plus important de disposer d'espaces sportifs en plein air sûrs, accessibles et gratuits, où l'on peut faire de l'exercice, se détendre et rompre avec le stress quotidien. Et cela quel que soit l'âge ou le niveau de forme physique.

C'est pour cette raison que depuis 15 ans, nous nous consacrons à la création d'équipements de fitness et de loisirs en plein air de qualité, polyvalents et accessibles pour tous les niveaux. Des enfants et adolescents aux adultes sportifs et aux personnes âgées, nous avons une ligne dédiée pour tout le monde (même pour les chiens!).

Présent dans presque toute l'Europe grâce à nos nombreux distributeurs, nos bureaux principaux sont basés à Paris et Chrzanów, en Pologne, où se trouvent le siège et les entrepôts. À ce jour, nous avons installé plus de 3600 parcs sportifs en accès libre et nous continuons de croître à l'échelle mondiale. Tout en innovant et en introduisant constamment de nouveaux produits, nous espérons pouvoir offrir du sport gratuit aux quatre coins du monde! Parce que le sport devrait être accessible, à tous, partout.

EN

It is our core belief that physical activity is crucial for health and mental wellness as well as social interactions. Especially today, it is ever more important to have virus-safe, accessible and free outdoor sport spaces, where one can exercise, relax and break away from everyday stress. And that is regardless of age or level of fitness.

It is for this reason that for the past 15 years we have been dedicated to creating qualitative, versatile and accessible outdoor fitness and leisure equipment for all levels. From kids and adolescents to sportive adults and elderly, we have a dedicated line for everyone (even for dogs!).

Present in almost all of Europe thanks to our many distributors, our main offices are based in Paris and Chrzanów, Poland where the headquarters and warehouses are based. Till this day we have installed over 3600 free-access sport parks and we continue to grow globally. While constantly innovating and introducing new products, we hope to be able to bring free sport to every corner of the world! Because sport should be accessible, to everyone, everywhere.

Victoria Syska & Antoine Allaux
International Managing Directors
Herkules Fitness

PRODUCTION ET QUALITÉ

PRODUCTION AND QUALITY

Tous nos équipements sont fabriqués à partir de tubes en acier inoxydable ou en acier galvanisé à chaud de 3 mm d'épaisseur, qui sont ensuite soudés dans des machines individuelles. Les mâts principaux ont un diamètre de 114 mm, ce qui garantit robustesse et longévité. Toutes les pièces structurales ont jusqu'à 10 ans de garantie et sont résistantes aux intempéries.

All of our equipment is made from either stainless steel or hot-dip galvanized steel pipes 3mm thick, which are then welded into individual machines. The main poles are 114 mm in diameter which grants sturdiness and longevity. All structural parts have up to 10 years warranty and are weather-resistant.

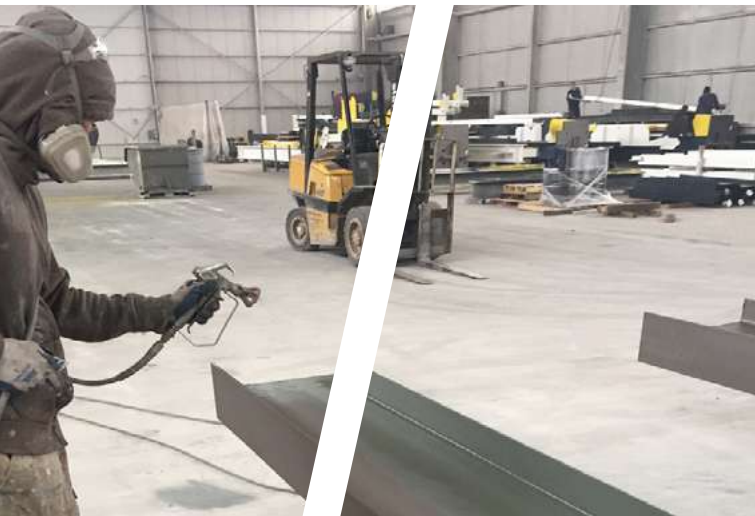

Les pièces soudées sont ensuite nettoyées des résidus graisseux par sablage. Pour protéger davantage l'équipement, chaque machine est recouverte d'une couche primaire à base de zinc.

The welded parts are then cleaned of greasy residues by sandblasting. To further protect the equipment, each machine is coated with a zinc-based primer.

En dehors de la série en acier inoxydable, chaque équipement est ensuite recouvert d'une épaisse couche de peinture statique Dupont qui est ensuite cuite dans un four à 200 degrés.

Apart from the stainless steel series, each piece of equipment is then covered with a thick layer of Dupont static paint which is then baked in an oven at 200 degrees.



PRODUCTION ET QUALITÉ

PRODUCTION AND QUALITY



Tous nos roulements sont des roulements fermés en acier inoxydable fabriqués par le fabricant renommé DSK Japan. De plus, toutes les vis et roulements sont protégés par des couvercles antivols 100% inoxydables. Les poignées sont fabriquées à partir de caoutchouc 100% recyclable, ce qui garantit une prise ferme et confortable pendant l'exercice.

All of our bearings are closed stainless steel bearings made by renowned manufacturer DSK Japan. Additionally, all of the screws and bearings are protected by 100% stainless anti-theft covers. The handles are made from 100% recyclable rubber which ensures a firm and comfortable grip during exercise.



DESIGN ET INNOVATION

DESIGN AND INNOVATION

L'innovation est au centre de notre métier. Afin de répondre aux besoins du plus grand nombre, et à des usages en évolution permanente, nous développons constamment de nouvelles lignes, en utilisant les dernières technologies et des solutions toujours plus créatives. Les pistons en aluminium, les poids réglables sécurisés ou le chargement de téléphone sans contact intégré à nos appareils ne sont que quelques-uns de nos derniers développements!

Tous nos appareils sont conçus en collaboration avec des sportifs professionnels, afin de proposer des exercices efficaces, adaptés à toutes les morphologies et à tous les niveaux. Depuis notre création en 2007, nous avons progressivement élargi notre offre afin de proposer des appareils toujours plus performants. Aujourd'hui, nos agrès s'adressent aussi bien aux promeneurs et sportifs du dimanche qu'à des athlètes de haut niveau voulant pratiquer en extérieur.

Nos équipements sont imaginés, prototypés et testés par nos équipes dans un seul but : rendre le sport extérieur accessible et performant pour tous!

Innovation is at the heart of our business. In order to meet the needs of the greatest number, and to constantly changing uses, we are constantly developing new lines, using the latest technologies and ever more creative solutions. Aluminum pistons, secure adjustable weights or the contactless phone charging built into our devices are just a few of our latest developments!

All our devices are designed in collaboration with professional athletes, in order to offer effective exercises, adapted to all body types and to all levels. Since our creation in 2007, we have gradually expanded our offer in order to offer ever more efficient devices. Today, our apparatus is aimed at both walkers and Sunday athletes as well as high-level athletes who want to practice outdoors.

Our equipment is designed, prototyped and tested by our teams with a single goal: to make outdoor sport accessible and efficient for all!

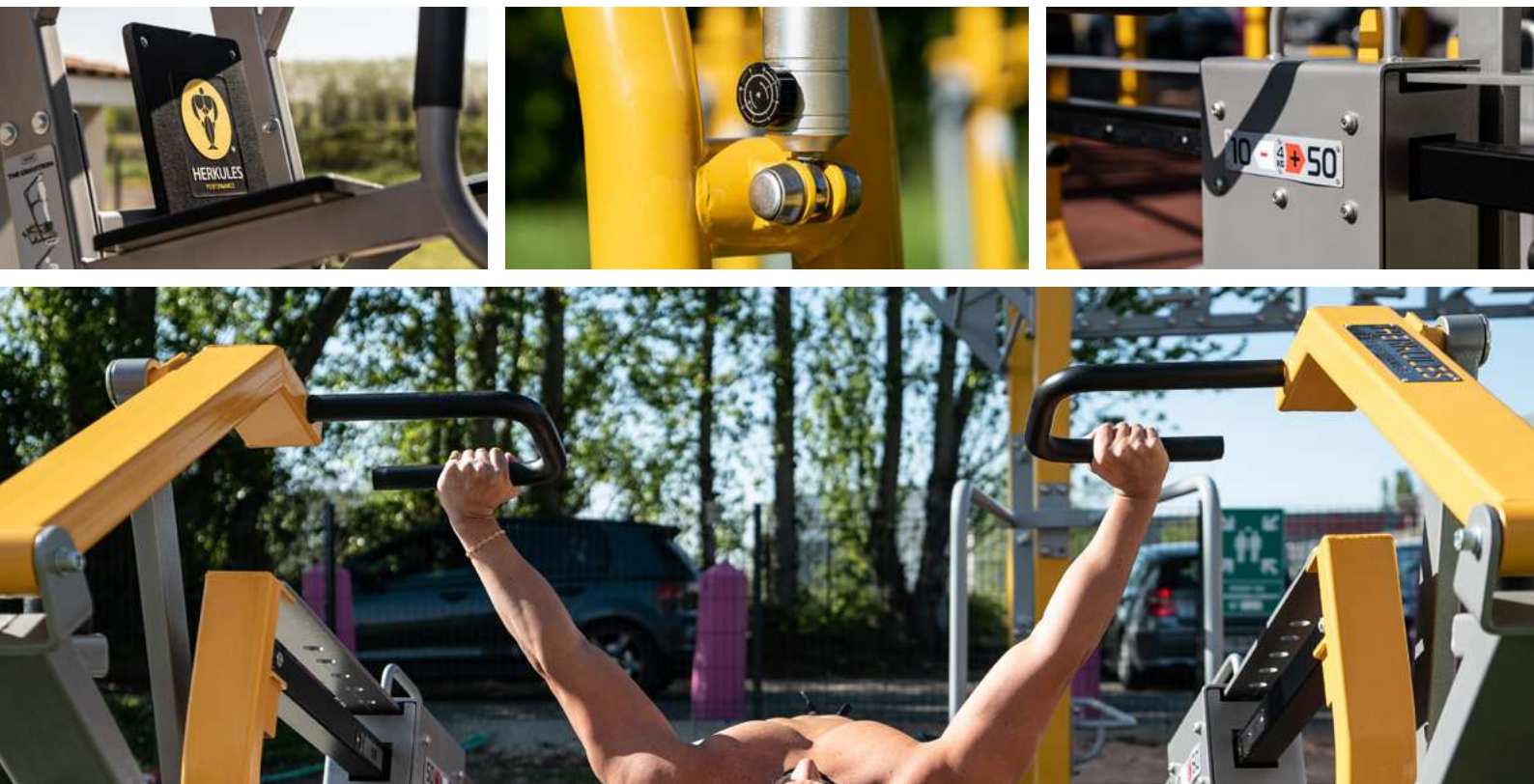

CERTIFICATION ET SÉCURITÉ

CERTIFICATION AND SAFETY

Que nos parcs sportifs soient installés dans des clubs sportifs, des hôtels, des bases militaires ou au milieu de l'espace public, chacun doit pouvoir pratiquer en toute sécurité. C'est pour cela que la sécurité est au cœur de nos préoccupations. Nos appareils sont conçus avec les meilleurs matériaux et procédés de fabrication, afin de leur conférer une grande durabilité dans le temps et d'offrir une utilisation en toute sécurité tout au long de leur vie.

Chaque agrès Herkules a été testé contre une utilisation intensive et les intempéries, afin de répondre au cahier des charges défini par nos équipes et d'obtenir leur certification à la norme européenne EN 16630:2015.

La réglementation européenne définit dans l'article EN 16630:2015 les conditions de sécurité à remplir dans la production, l'assemblage et l'installation d'appareils sportifs d'extérieur. Tous les appareils Herkules sont conçus pour répondre scrupuleusement à ces règles, afin d'assurer la sécurité de nos utilisateurs : hauteurs de chute, zones de coincement, roulements avec butée, valises de poids sécurisées.

Whether our sports parks are located in sports clubs, hotels, military bases or in the middle of public space, everyone must be able to practice in complete safety. This is why security is at the heart of our concerns. Our devices are designed with the best materials and manufacturing processes, to give them great durability over time and offer safe use throughout their life.

Each Herkules apparatus has been tested against intensive use and bad weather, in order to meet the specifications defined by our teams and to obtain their certification to European standard EN 16630: 2015.

European regulations define in article EN 16630: 2015 the safety conditions to be fulfilled in the production, assembly and installation of outdoor sports equipment. All Herkules devices are designed to strictly comply with these rules, in order to ensure the safety of our users: fall heights, jamming zones, bearings with stopper, secure weight cases.



AFFICHAGE DISPLAY



Chaque agrès Herkules Fitness est équipé d'un panneau d'information fixe et durable. Chaque plaque comprend des informations sur les exercices, sa fonction, des conseils sur la façon de faire de l'exercice ainsi qu'un code QR qui mène à une application Herkules Fitness gratuite avec des vidéos tutorielles. Les panneaux sont en 2-3 langues et contiennent les mentions légales nécessaires, les restrictions concernant l'utilisation de l'équipement et les coordonnées d'urgence.

Each Herkules Fitness machine is equipped with a permanently fixed, durable informational panel. Every plate includes information regarding the exercises, its function, advice on how to exercise as well as a QR code which leads to a free Herkules Fitness App with tutorial videos. Panels are in 2-3 languages and contain the necessary legal notice, restrictions regarding the use of equipment and emergency contact information.



En plus de l'affichage sur les appareils, la présence d'un panneau d'information général est obligatoire sur une aire fitness. Notre panneau est entièrement personnalisable selon vos besoins. En plus des informations requises légalement, nous pouvons personnaliser le panneau avec votre logo, vos couleurs, et les toute information complémentaire.

In addition to the display on the equipment, the presence of a general information panel is mandatory on a fitness area. Our panel is fully customizable according to your needs. In addition to the legally required information, we can customize the sign with your logo, colors, and additional information.



ACCOMPAGNEMENT PROJECT SUPPORT

Avec plus de 15 ans d'expérience, nous connaissons le monde du fitness en plein air mieux que quiconque. Par conséquent, nous sommes là pour vous aider à choisir et à concevoir l'espace fitness de vos rêves. Nous vous accompagnons dans le choix des appareils et de leur disposition, afin que ceux-ci répondent aux besoins de votre public, tout en s'intégrant au mieux dans leur environnement. Nous pouvons également fournir des intégrations 3D sur photo pour mieux vous projeter dans votre futur parc fitness.

With over 15 years of experience, we know the outdoor fitness world better than anyone. Therefore, we are here to help you choose and design your dream fitness area. We support you in the choice of equipment and its arrangement, so that it meets the needs of your audience, while integrating as well as possible into their environment. We can also provide 3D photo integrations to better project you in your future fitness park.



INSTALLATION

L'installation est une étape cruciale dans la mise en place de votre parc fitness, afin de garantir longévité et sécurité. Nos équipes d'installateurs partenaires réparties à travers toute l'Europe sont formés spécifiquement à nos produits, afin de garantir une installation dans les règles de l'art.

Deux méthodes d'installation sont possibles en fonction du type d'appareil et de la nature du sol. Les pieds peuvent être fixés par scellement chimique directement dans une dalle en béton ou boulonnés à des tabourets d'ancrage Herkules sur un sol naturel.

Le revêtement de finition du sol joue également un rôle essentiel, autant pour l'esthétique, l'entretien, l'accessibilité et la sécurité. En effet, à partir d'une certaine hauteur de chute, le sol doit avoir certaines propriétés amortissantes. Nos installateurs ont tout le savoir faire pour vous proposer différents types de finition : gazon naturel, synthétique, sol souple EPDM, gravillons, pavés, sable...

Installation is a crucial step in setting up your fitness park, in order to guarantee longevity and safety. Our partner installers throughout Europe are trained to ensure proper installation.

Two installation methods are possible depending on the type of device and the type of soil. The legs can be chemically sealed directly into a concrete slab or bolted to Herkules anchor stools.

The floor finish also plays an essential role, as much for aesthetics, maintenance, accessibility and safety. Indeed, from a certain fall height, the ground must have certain damping properties. Our installers have all the know-how to offer you different types of finish: natural turf, synthetic turf, flexible EPDM soil, gravel, paving stones, sand, etc.

OUR INSTALLATION PARTNERS:



Béton



Dalles EPDM



Gazon synthétique



EPDM



Gravillons



Pavés



Gazon Naturel



Sable



VIDEO PROFESSIONELLE

PROFESSIONAL VIDEO

Nous savons à quel point un projet de parc fitness en plein air peut être passionnant et engageant! Il se passe parfois plusieurs mois entre le premier contact et l'ouverture du parc, et un tel projet mérite d'être mis en valeur. C'est pourquoi nous proposons un service de réalisation de vidéo, afin que vous puissiez communiquer sur votre nouveau parc fitness au sein de votre communauté.

Nos vidéos sont réalisées et montées par des vidéastes professionnels disposant de caméra haute définition, de stabilisateurs électroniques et de drones. De quoi vous fournir un support de communication idéal pour partager sur vos réseaux sociaux et sites internet.

Vous voulez voir à quoi cela ressemble? Visitez notre page Youtube!

We know how exciting and engaging an outdoor fitness park project can be! Sometimes several months pass between the first contact and the opening of the park, and such a project deserves to be highlighted. This is why we offer a video production service, so that you can communicate about your new fitness park within your community.

Our videos are made and edited by professional videographers with high definition cameras, electronic stabilizers and drones. Enough to provide you with an ideal communication medium to share on your social networks and websites.

Want to see what it looks like? Visit our Youtube page!



Herkules Fitness

herkules fitness

ZALOGUJ SIĘ

Główna
Odkrywaj
Subskrypcje
Biblioteka
Historia

Zaloguj się, by polubić film, zostawić komentarz lub zasubskrybować kanał.

ZALOGUJ SIĘ

NAJLEPSZE W YOUTUBE

Muzyka
Sport
Gry
Filmy
Wiadomości
Na żywo
Film 360°
Przeglądaj kanały

Herkules Fitness

SUBSKRYBUJ

GLÓWNA WIDEO PLAYLISTY KANAŁY DYSKUSJA INFORMACJE

California Gym - La première salle de musculation extérieure...
1762 wyświetlenia • 1 miesiąc temu

California Gym est une salle de sport gérée depuis plus de 30 ans par Alex Sentenac, ancien champion de France de Bodybuilding.

Il a décidé d'équiper l'extérieur de sa salle avec des appareils Herkules Street Workout et Performance afin de continuer d'accueillir ses adhérents passionnés.

POKAŻ WIĘCEJ

Installations ▶ ODTWÓRZ WSZYSTKIE

Découvrez nos installation fitness en plein air à travers la France en vidéo.

APPLICATION HERKULES FITNESS

- EXPLICATIONS VIDÉO
- QR CODES
- LOCALISATION DE PARCS FITNESS
- ENTRAÎNEMENT PERSONNALISÉ
- CONSEILS BIEN-ÊTRE ET NUTRITION

APPLICATION HERKULES FITNESS

- VIDEO EXPLANATION
- QR CODES
- LOCALISATION OF FITNESS PARKS
- PERSONNALISED TRAINING
- NUTRITION AND WELL-BEING TIPS



Dans un contexte de dérèglement climatique, Herkules Fitness s'engage dans une démarche responsable et durable, afin de limiter nos effets négatifs sur l'environnement.

Nos appareils sont recyclables à 99% et nos emballages sont issus de matériaux recyclés.

De plus, nous soutenons l'action de Reforest'Action, une organisation non gouvernementale engagée dans la protection des forêts à travers le monde. Concrètement, elle plante des arbres dans des zones protégées, afin de créer des forêts, éléments indispensables à la vie sur Terre, véritables poumons de la planète.

En plus de nos dons réguliers, nous finançons la plantation d'un arbre pour chaque appareil Herkules installé. Lors de la mise en place de votre projet, vous pouvez choisir le lieu de plantation, et recevoir un certificat Reforest'Action.

In the context of increasing climate change, the preservation and creation of forests is one of the most vital measures to prevent this devastating man-made process.

At Herkules Fitness, we understand the impacts of our business on the environment and are committed to limiting its negative footprint.

Therefore, 100% of our machines are recyclable and their packaging comes from recycled sources. In addition, we actively support the work of Reforest'Action which is an organization with the objective of planting trees in the most crucial regions of the world. In addition to our regular donations, we buy one tree per installed machine. For each fitness park, you can choose the destination where you want to plant the trees and receive a Reforest'Action certificate.



**1 APPAREIL
INSTALLÉ
=
1 ARBRE
PLANTÉ**



HERKULES
FITNESS EN PLEIN AIR





Une série complète d'exercices
accessibles à tous les niveaux,
pour pratiquer le sport tout en douceur.

A versatile series of machines
accessible to all levels,
to practice sport smoothly.

FITNESS





DOUBLE PUSH

Ref: THJ-BO1

Dim: 2306 x 762 x 1909 mm



PUSH SIMPLE

Ref: THJ-BO1S

Dim: 1303 x 762 x 1909 mm



DOUBLE PULL

Ref: THJ-BO2

Dim: 2315 x 742 x 1909 mm



PULL SIMPLE

Ref: THJ-BO2S

Dim: 1307 x 742 x 1909 mm





PUSH + PULL

Ref: THJ-BO1 + BO2

Dim: 2317 x 762 x 1909 mm



STRETCH

Ref: THJ-BO3

Dim: 949 x 924 x 1220 mm



VÉLO ELLIPTIQUE

Ref: THJ-BO4

Dim: 1170 x 641 x 1655 mm



MASSEUR DOS ET HANCHES

Ref: THJ-BO5

Dim: 1462 x 783 x 1491 mm





TRIPLE BARRE DE TRACTION

Ref: THJ-BO6

Dim: 1877 x 1649 x 2210 mm



RAMEUR

Ref: THJ-BO8

Dim: 1406 x 1087 x 10112 mm



CHEVAL D'ARÇON

Ref: THJ-BO9

Dim: 1460 x 610 x 1196 mm



DOUBLE SURFEUR

Ref: THJ-B10

Dim: 1272 x 852 x 1488 mm

FITNESS



MARCHEUR

Ref: THJ-B11

Dim: 1207 x 482 x 1442 mm



STEPPER + MACHEUR + TWISTER

Ref: THJ-B10 + B11 + B16

Dim: 2635 x 806 x 1397 mm



ROUES TAI CHI

Ref: THJ-B12

Dim: 1285 x 1160 x 1416 mm



GRANDE ROUE + ROUE TAI CHI

Ref: THJ-B12 + B19

Dim: 1160 x 1137 x 1761 mm





DOUBLE LEG PRESS

Ref: THJ-B13

Dim: 2348 x 472 x 1791 mm



LEG PRESS SIMPLE

Ref: THJ-B13S

Dim: 1324 x 472 x 1791 mm



PLANCHE ABDO SIMPLE

Ref: THJ-B14S

Dim: 1538 x 1048 x 581 mm



DOUBLE PLANCHE ABDO

Ref: THJ-B14

Dim: 1533 x 1237 x 757 mm



ABDOS + LOMBAIRE

Ref: THJ-D10/B

Dim: 1973 x 1533 x 1057 mm



ÉCHELLE DOUBLE

Ref: THJ-D14/B

Dim: 1582 x 1019 x 2081 mm



CHAISE ROMAINE DOUBLE

Ref: THJ-D14/B

Dim: 2541 x 665 x 1957 mm



ÉCHELLE + CHAISE ROMAINE

Ref: THJ-D14/B

Dim: 2062 x 1019 x 2081 mm





PLANCHE RENVERSÉE

Ref: THJ-B15

Dim: 1189 x 796 x 1739 mm



TRIPLE TWISTER

Ref: THJ-B16

Dim: 1807 x 1570 x 1364 mm



TWISTER + SURFEUR

Ref: THJ-B10 + B16

Dim: 1584 x 853 x 1502 mm



TWISTER + STEPPER

Ref: THJ-B16 + B25

Dim: 1428 x 853 x 1487 mm

FITNESS



BARRES PARALLÈLES

Ref: THJ-B17

Dim: 1950 x 562 x 1608 mm



CAVALIER

Ref: THJ-B18

Dim: 1305 x 665 x 1297 mm



GRANDES ROUES

Ref: THJ-B19

Dim: 900 x 891 x 1761 mm



PAPILLON

Ref: THJ-B20

Dim: 1665 x 1441 x 1957 mm





PATINEUR

Ref: THJ-B22

Dim: 1164 x 590 x 1655 mm



DOUBLE PATINEUR

Ref: THJ-B22

Dim: 1266 x 554 x 1647 mm



LEG LIFT

Ref: THJ-B23

Dim: 884 x 828 x 1198 mm



DOUBLE ADDUCTEUR

Ref: THJ-B24

Dim: 1289 x 666 x 1364 mm

FITNESS



STEPPER

Ref: THJ-B255

Dim: 757 x 592 x 1331 mm



DOUBLE STEPPER

Ref: THJ-B25

Dim: 1214 x 590 x 1331 mm



DOUBLE TWISTER MASSANT

Ref: THJ-B26

Dim: 1517 x 798 x 1556 mm



ECHELLE À ÉTIREMENT

Ref: THJ-B27

Dim: 685 x 420 x 1963 mm





VÉLO

Ref: THJ-B28

Dim: 1076 x 516 x 1296 mm



ARM PRESS

Ref: THJ-B29

Dim: 1556 x 774 x 1023 mm



LOW PULL UP

Ref: THJ-B30

Dim: 1278 x 662 x 962 mm



ABDOMINAL

Ref: THJ-B31

Dim: 1210 x 612 x 1605 mm

FITNESS



TWISTER DEBOUT & ASSIS

Ref: THJ-B32

Dim: 1726 x 742 x 1343 mm



PMR



VÉLO BRAS

Ref: THJ-B33

Dim: 817 x 610 x 1375 mm



PÉDALES DE BANC (2 PIÈCES)

Ref: THJ-B34

Dim: 525 x 410 x 296 mm



PMR





Créez votre espace fitness sur mesure avec des milliers de combinaisons possibles grâce à nos pylônes 2, 3 et 4 faces.

Create your tailor-made fitness space with thousands of possible combinations thanks to our 2, 3 and 4-sided pylons.

FITNESS MIX



QUAD
PULL

FUNKTION
Anwendung: ...
Anwendung: ...
Anwendung: ...

BEWEGUNG
Anwendung: ...
Anwendung: ...
Anwendung: ...

ANWENDUNG
Anwendung: ...
Anwendung: ...
Anwendung: ...

BEWEGUNG
Anwendung: ...
Anwendung: ...
Anwendung: ...

ANWENDUNG
Anwendung: ...
Anwendung: ...
Anwendung: ...



PYLÔNE 2 FACES

Ref: THJ-CO2

Dim: 300 x 550 x 1997 mm



PYLÔNE 3 FACES

Ref: THJ-CO3

Dim: 555 x 555 x 1940 mm



PYLÔNE 4 FACES

Ref: THJ-CO4

Dim: 570 x 570 x 1940mm

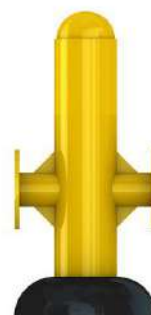

POTEAU 5

Ref: THJ-PO1

Dim: 350 x 300 x 580 mm



POTEAU M

Ref: THJ-PO2

Dim: 350 x 300 x 1470 mm

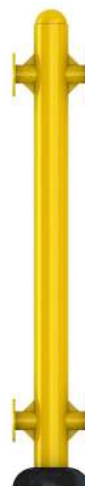

POTEAU L

Ref: THJ-PO3

Dim: 350 x 300 x 1960 mm



PUSH

Ref: THJ-DO1

Dim: 2313 x 760 x 1997 mm



PULL

Ref: THJ-DO2

Dim: 2314 x 742 x 1997 mm





SURFEUR

Ref: THJ-DO3

Dim: 1643 x 801 x 1997 mm



MARCHEUR

Ref: THJ-DO4

Dim: 2765 x 830 x 1997 mm



LEG PRESS

Ref: THJ-DO5

Dim: 2359 x 550 x 1997 mm



VÉLO

Ref: THJ-DO6

Dim: 1961 x 1201 x 1997 mm





ADDUCTEUR ASSIS

Ref: THJ-DO7

Dim: 3130 x 1218 x 1997 mm



PAPILLON

Ref: THJ-DO8

Dim: 2901 x 1424 x 1997 mm



MASSEUR DOS

Ref: THJ-DO9

Dim: 1754 x 804 x 1997 mm



PLANCHE ABDO

Ref: THJ-D10

Dim: 1450 z 1533 x 1997 mm



LOMBAIRE

Ref: THJ-D10

Dim: 1850 x 821 x 1997 mm



VÉLO ELLIPTIQUE

Ref: THJ-D11

Dim: 3707 x 641 x 1997 mm



MASSEUR HANCHE

Ref: THJ-D12

Dim: 2401 x 636 x 1997 mm



II MASSEUR DOS

Ref: THJ-D12

Dim: 1700 x 765 x 1997 mm



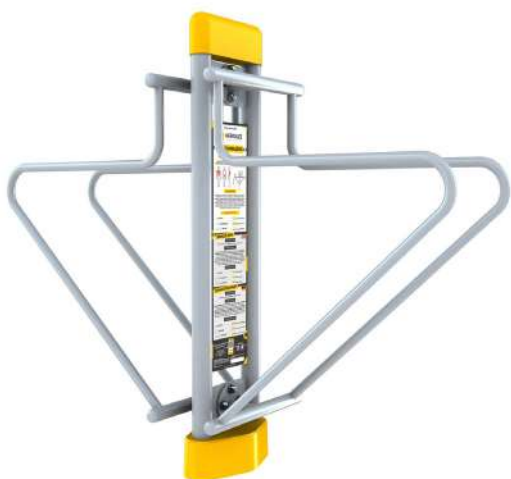

BARRES PARALLÈLES

Ref: THJ-D13

Dim: 2394 x 714 x 1997 mm



ÉCHELLE

Ref: THJ-D14

Dim: 1152 x 998 x 2081 mm



CHAISE ROMAINE

Ref: THJ-D14

Dim: 2331 x 675 x 1997 mm



CAVALIER

Ref: THJ-D15

Dim: 3159 x 665 x 1997 mm



RACK À TRACTION

Ref: THJ-DI6

Dim: 1488 x 787 x 2174 mm



GRANDE ROUE

Ref: THJ-DI8

Dim: 1454 x 903 x 1997 mm



ROUES TAI CHI

Ref: THJ-DI8

Dim: 1565 x 1154 x 1997 mm



ARMS TRAINER

Ref: THJ-DI9

Dim: 1344 x 989 x 2653 mm





MASSEUR AVEC TWISTER

Ref: THJ-D20

Dim: 2084 x 550 x 1997 mm



TWISTER

Ref: THJ-D21

Dim: 1787 x 591 x 1997 mm



II STEPPER

Ref: THJ-D21 II

Dim: 1660 x 559 x 1997 mm



PATINEUR

Ref: THJ-D22

Dim: 3020 x 554 x 1997 mm



RAMEUR

Ref: THJ-D23

Dim: 2522 x 759 x 1997 mm



ADDUCTEUR

Ref: THJ-D24

Dim: 1950 x 653 x 1997 mm



MOULINET

Ref: THJ-D25

Dim: 1698 x 653 x 1997 mm



BICEPS

Ref: THJ-D26

Dim: 2605 x 526 x 1997 mm





BENCH PRESS

Ref: THJ-D27

Dim: 3094 x 827 x 1997 mm



LEG EXTENSION

Ref: THJ-D28

Dim: 2184 x 886 x 1997 mm



ARM PRESS

Ref: THJ-D29

Dim: 3494 x 774 x 1997 mm



LOW PULL UP

Ref: THJ-D30

Dim: 3652 x 672 x 1997 mm

FITNESS MIX





Fabrication en acier inoxydable
(304) - une grande durabilité
dans tout type d'environnement.

Stainless steel (304)
construction for a great longevity
in all types of environments.

FITNESS INOX





RAMEUR

Ref: SN-O1

Dim: 1319 x 930 x 1103 mm



VELO ELLIPTIQUE

Ref: SN-O3

Dim: 1300 x 636 x 1709 mm



LEG PRESS

Ref: SN-O4

Dim: 1865 x 895 x 2030 mm



SURFEUR

Ref: SN-O5

Dim: 1263 x 698 x 1540 mm

FITNESS INOX



PUSH PULL

Ref: SN-06

Dim: 2366x 1007 x 2257 mm



ROUES TAI CHI

Ref: SN-07

Dim: 1041 x 1042 x 1467 mm



DOUBLE TWISTER

Ref: SN-08

Dim: 1498 x 784 x 1730 mm



MARCHEUR

Ref: SN-09

Dim: 1248 x 500 x 1486 mm





MARCHEUR DOUBLE

Ref: SN-O9 duo

Dim: 2338 x 500 x 1351 mm



VÉLO

Ref: SN-10

Dim: 1024 x 550 x 1329 mm



MASSEUR

Ref: SN-11

Dim: 1427 x 795 x 1565 mm



SURFEUR + TWISTER + MARCHEUR

Ref: SN-O5 + SN-O8 + SN-O9

Dim: 2526 x 785 x 1470 mm

FITNESS INOX





Des appareils créés
spécifiquement pour les seniors et les
personnes à mobilité réduite.

A range of equipment
created specifically for elderly
and people with disabilities.

SENIOR + PMR

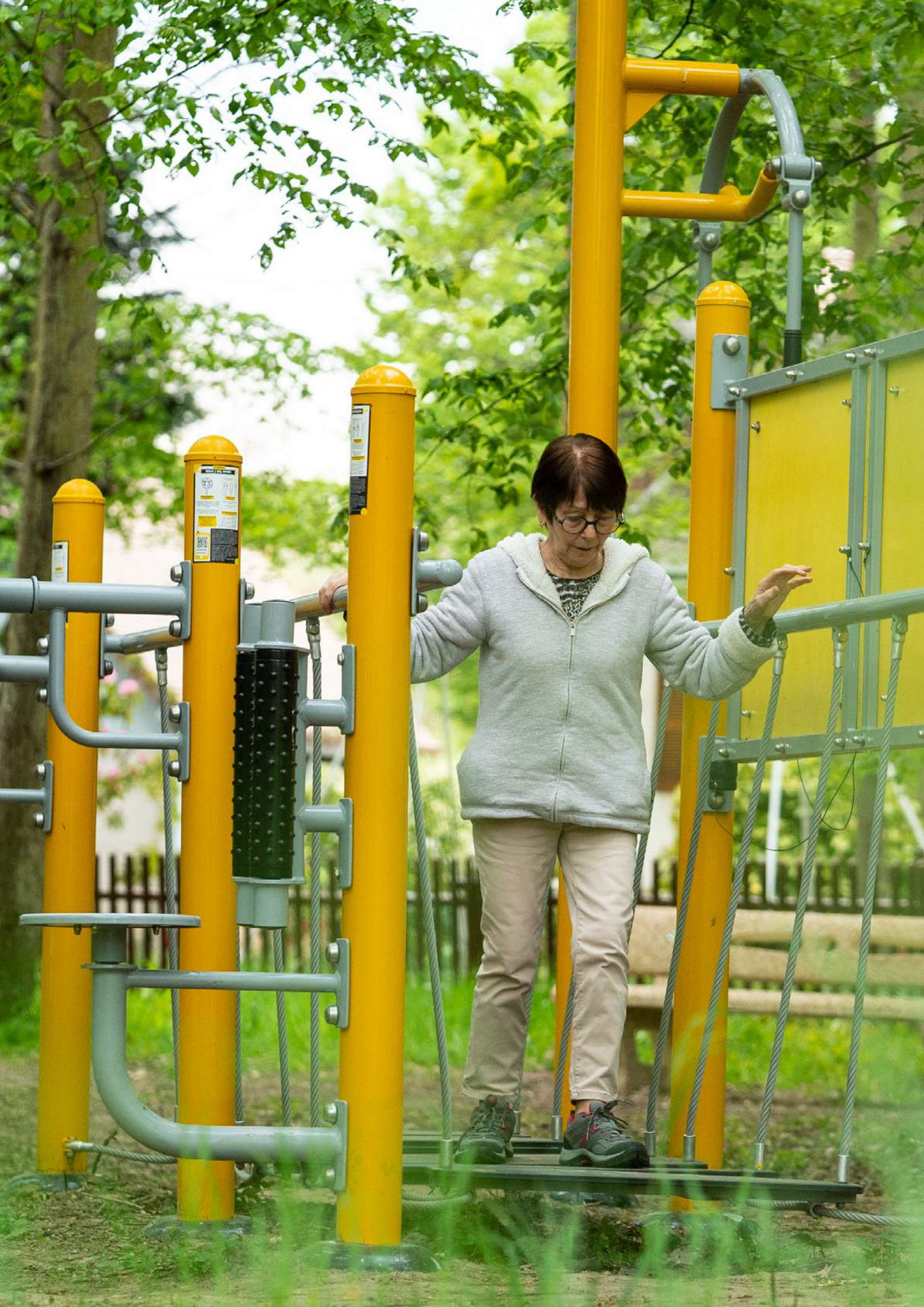



STATION EQUILIBRE

Ref: SEN-O1

Dim: 4282 x 2567 x 2500 mm

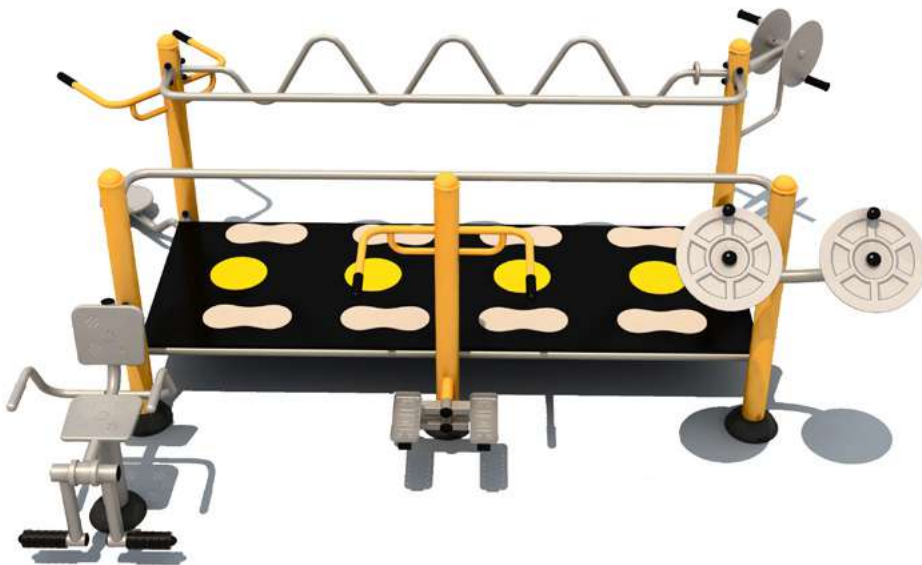

STATION MOBILITÉ

Ref: SEN-O2

Dim: 4176 x 3029 x 1450 mm

SENIOR + PMR



RAMPE

Ref: SEN-O3

Dim: 3118 x 1135 x 1850 mm



STATION RELAX

Ref: SEN-O4

Dim: 3492 x 2695 x 1700 mm



STATION BRAS

Ref: SEN-O5

Dim: 3700 x 1100 x 1700 mm

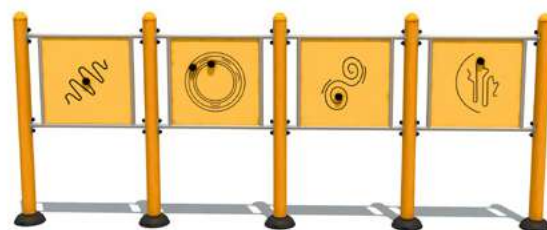

PANNEAUX JEUX

Ref: SEN-O6

Dim: 4390 x 114 x 1800 mm



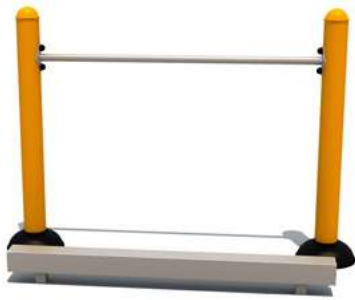

POUTRE

Ref: SEN-O7

Dim: 1800 x 557 x 1250mm



SAUT DE HAIES

Ref: SEN-O8

Dim: 2814 x 1220 x 1250 mm



PUSH

Ref: THJ-NO1

Dim: 1718 x 801 x 1997 mm



PULL

Ref: THJ-NO2

Dim: 2111 x 742 x 1997 m

SENIOR + PMR



EPAULES

Ref: THJ-NO3

Dim: 1525 x 682 x 1997 mm



TRACTION / STRETCH

Ref: THJ-DI6/N

Dim: 1678 x 790 x 1997 mm



ARMS TRAINER

Ref: THJ-DI9/N

Dim: 1280 x 790 x 1997 mm



ROUES TAI CHI

Ref: THJ-DI8M/N

Dim: 1566 x 1155 x 1997 mm





GRANDES ROUES

Ref: THJ-D18D/N

Dim: 1445 x 900 x 1997 mm



STEPPER

Ref: THJ-N21

Dim: 2295 x 657 x 1997 mm



RAMEUR

Ref: THJ-D23/N

Dim: 1220 x 1269 x 799 mm



MOULINET

Ref: THJ-D25/N

Dim: 1580 x 650 x 1997 mm

SENIOR + PMR



BICEPS

Ref: THJ-N26

Dim: 1430 x 600 x 1997 mm



PATINEUR

Ref: THJ-N22

Dim: 889 x 843 x 1376 mm



4 EN 1

Ref: KOMBI4INI

Dim: 1521 x 994 x 1249 mm

NOUVEAUTÉ



JEUX DE MOBILITÉ

Ref: SENO9

Dim: 2300 x 2550 x 1050 mm





Règlez la dureté du piston
pour mettre un peu de challenge
dans votre entraînement quotidien.

Put a little bit of challenge
in your daily training
thanks to our adjustable pistons.

PISTON



Hydraulische
Langhantel für Liegen

AOS



PAPILLON

Ref: HEH-O1

Dim: 1140 x 555 x 1533 mm



ABDO

Ref: HEH-O2

Dim: 1133 x 614 x 1533 mm



LEG PRESS

Ref: HEH-O3

Dim: 1325 x 646 x 1533 mm



SQUAT

Ref: HEH-O4

Dim: 1125 x 766 x 1533 mm

PISTON



ADDUCTEUR

Ref: HEH-05

Dim: 1461 x 1050 x 1533 mm



TRICEPS

Ref: HEH-08

Dim: 922 x 642 x 1533 mm



CHEST PRESS

Ref: HEH-09

Dim: 1072 x 642 x 1533 mm



PUSH

Ref: HEH-10

Dim: 1065 x 642 x 1532 mm





EPAULES

Ref: HEH-11

Dim: 1065 x 1007 x 1533 mm



BICEPS

Ref: HEH-12

Dim: 958 x 640 x 1153 mm



RAMEUR

Ref: HEH-14

Dim: 1297 x 692 x 1247 mm



STEPPER

Ref: HEH-15

Dim: 1106 x 664 x 1531 mm

PISTON



BENCH

Ref: HEH-16

Dim: 1411 x 896 x 1193 mm



CUISSES

Ref: HEH-17

Dim: 1215 x 666 x 1533 mm



VÉLO

Ref: HEH-18

Dim: 1423 x 587 x 1533 mm





Ajustez la difficulté avec notre résistance magnétique, tout en rechargeant votre téléphone en USB ou par induction.

Adjust the difficulty thank to the magnetic resistance, while charging your phone via USB or wireless charging.

CHARGE





VÉLO ELLIPTIQUE

Ref: USB-01

Dim: 2400 x 580 x 1655 mm



VÉLO

Ref: USB-02

Dim: 1800 x 728 x 1306 mm



VÉLO BRAS

Ref: USB-03

Dim: 1657 x 639 x 1276 mm



STEPPER

Ref: USB-04

Dim: 976 x 500 x 1356 mm

CHARGE



SQUAT

Ref: USB-05

Dim: 1327 x 460 x 1276 mm



RAMEUR

Ref: USB-06

Dim: 1700 x 822 x 1276 mm



CHEST PRESS

Ref: USB-07

Dim: 834 x 822 x 1276 mm



TIRAGE LATERAL

Ref: USB-08

Dim: 998 x 822 x 1615 mm





PRESSE EPAULE

Ref: USB-09

Dim: 980 x 822 x 1276 mm



PAPILLION

Ref: USB-10

Dim: 979 x 640 x 1390 mm



ADDUCTEUR

Ref: USB-11

Dim: 1122 x 419 x 1276 mm



LEG EXTENSION

Ref: USB-12

Dim: 1129 x 725 x 1306 mm

CHARGE



DEADLIFT

Ref: USB-13

Dim: 1298 x 435 x 1276 mm



TRICEPS

Ref: USB-14

Dim: 837 x 602 x 1276 mm





Une gamme conçue pour progresser,
avec des poids réglables et sécurisés pour
un entraînement poussé, en plein air.

A range dedicated to progression,
with adjustable secured weights,
for an intense outdoor workout.

BODYBUILDING





CHEST PRESS

Ref: HE-O1

Dim: 1270 x 1147 x 1555 mm



ÉPAULES

Ref: HE-O2

Dim: 1270 x 1103 x 1915 mm



DEAD LIFT

Ref: HE-O3

Dim: 1270 x 1227 x 1677 mm



PULL DOWN

Ref: HE-O4

Dim: 1610 x 1350 x 2445 mm

BODYBUILDING



PAPILLON

Ref: HE-O5

Dim: 1670 x 1350 x 2180 mm



CUISSSES

Ref: HE-O6

Dim: 1350 x 1112 x 1414 mm



LEG PRESS

Ref: HE-O7

Dim: 1270 x 1282 x 1690 mm



SQUAT

Ref: HE-O8

Dim: 1419 x 1160 x 1345 mm





BENCH PRESS

Ref: HE-O9

Dim: 1270 x 1620 x 1157mm



BODYBUILDING



**S'entraîner comme
à la salle!**



Notre gamme la plus avancée,
la plus professionnelle,
pour s'entraîner comme à la salle!

Our most advanced
and progressive range.
Create a professional outdoor gym!

PERFORMANCE



10 - 4 KG + 50



TRACTION / DIPS / LIFT LEG

Ref: HD1001

Dim: 1163 x 1213 x 2380 mm



LOMBAIRE / ABDOS

Ref: HD1002

Dim: 1050 x 1630 x 760 mm



DÉVELOPPÉ INCLINÉ

Ref: HD1003

Dim: 1500 x 1500 x 1725mm

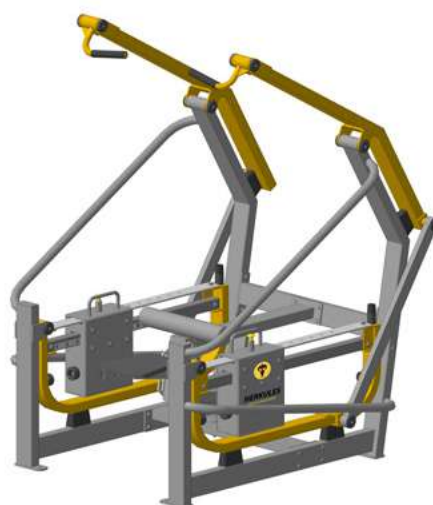

TIRAGE VERTICAL

Ref: HD1004

Dim: 1590 x 1340 x 2030 mm

PERFORMANCE

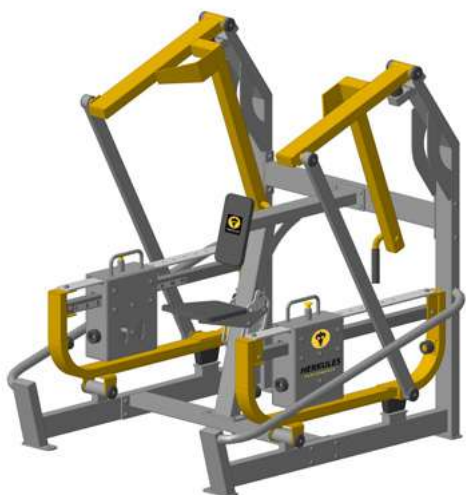

RAMEUR

Ref: HD1005

Dim: 1495 x 1500 x 1705 mm

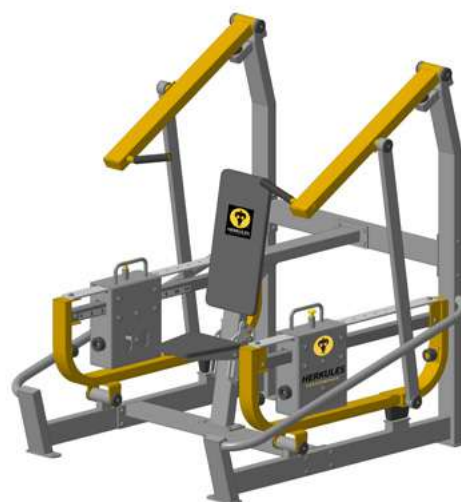

DÉVELOPPÉ ÉPAULES

Ref: HD1006

Dim: 1495 x 1500 x 1710 mm

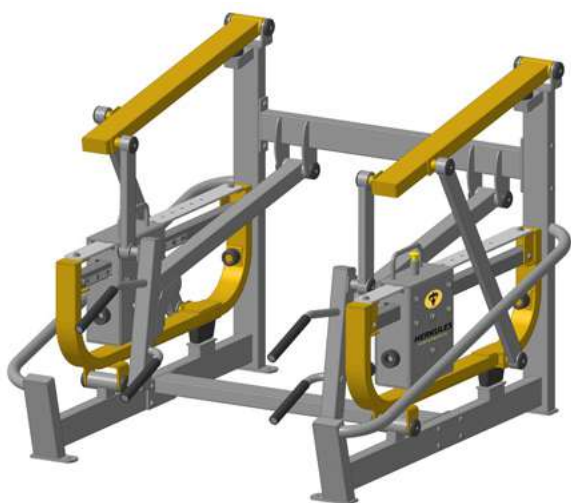

DEAD LIFT

Ref: HD1007

Dim: 1530 x 1500 x 1240 mm



SQUAT

Ref: HD1008

Dim: 1780 x 1500 x 1445 mm





EXTENSION GLUTE

Ref: HD1009

Dim: 1645 x 1340 x 1650 mm



PRESSE À CUISSES

Ref: HD1010

Dim: 1875 x 1500 x 1495 mm



TRICEPS

Ref: HD1011

Dim: 1500 x 1340 x 1470 mm

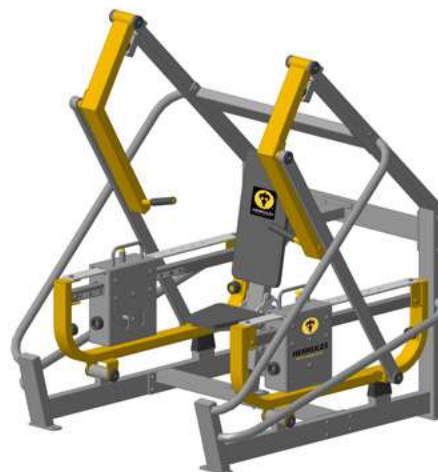

DÉVELOPPÉ POITRINE

Ref: HD1012

Dim: 1510 x 1500 x 1850 mm

PERFORMANCE



BICEPS

Ref: HD1013

Dim: 1490 x 1500 x 955 mm

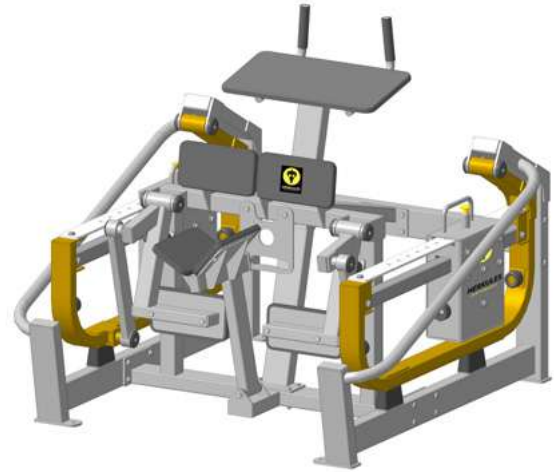

COURBE ISCHIO-JAMBIERS

Ref: HD1014

Dim: 1420 x 1500 x 1290 mm



EXTENSION DE JAMBES

Ref: HD1015

Dim: 1425 x 1340 x 1105 mm



DÉVELOPPÉ COUCHÉ

Ref: HD1016

Dim: 1820 x 1720 x 990 mm





GRAVITRON

Ref: HD1017

Dim: 1670 x 1410 x 2500 mm

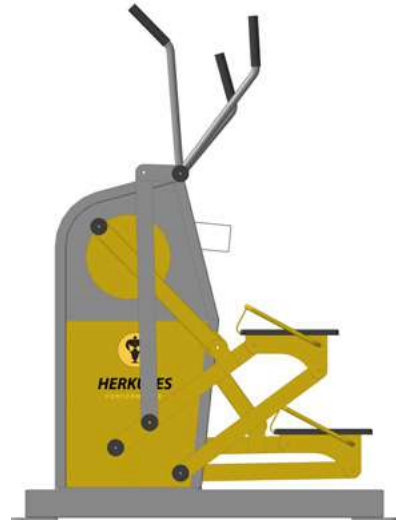

STEPPER

Ref: HD1018

Dim: 1370 x 730 x 1775 mm



VÉLO ELLIPTIQUE

Ref: HD1019

Dim: 1755 x 858 x 1565 mm



VÉLO HORIZONTAL

Ref: HD1020

Dim: 1670 x 628 x 1260 mm

PERFORMANCE



TAPIS ROULANT

Ref: HD1021

Dim: 1900 x 971 x 1473 mm



TRICEPS

PARALIMP

Ref: HD1101

Dim: 1500 x 1500 x 1470 mm

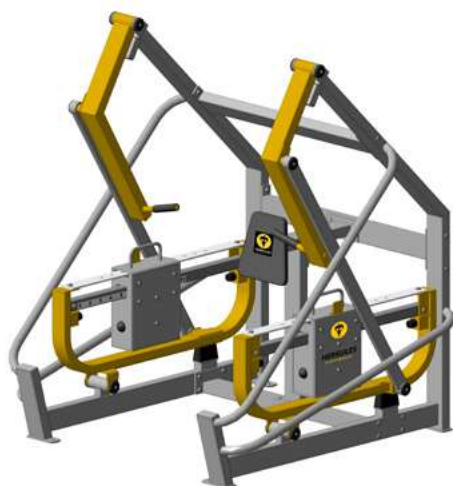

DÉVELOPPÉ POITRINE **PARALIMP**

Ref: HD1102

Dim: 1510 x 1500 x 1850 mm



DÉVELOPPÉ INCLINÉ **PARALIMP**

Ref: HD1103

Dim: 1495 x 1500 x 1715 mm



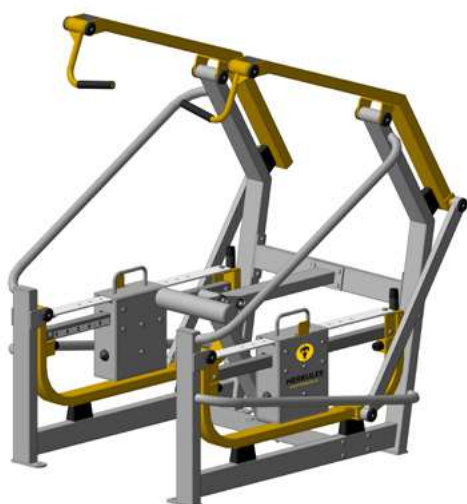

TIRAGE VERTICAL

PARALIMP

Ref: HD1104

Dim: 1595 x 1340 x 1880 mm



RAMEUR

PARALIMP

Ref: HD1105

Dim: 1495 x 1500 x 1605 mm



DÉVELOPPÉ ÉPAULES

PARALIMP

Ref: HD1106

Dim: 1495 x 1500 x 1550 mm



BICEPS

PARALIMP

Ref: HD1107

Dim: 1485 x 1500 x 955 mm



PERFORMANCE



”

**Une salle de sport gratuite
au coin de la rue!**



Mélangez sport,
fun et freestyle avec
le street workout.

Mix sport,
fun and freestyle
with street workout!

STREET WORKOUT





STATION CROSS TRAINING

Ref: HER-O1

Dim: 5837 x 3890 x 3628 mm



STATION STREET

Ref: HER-O2

Dim: 5960 x 4154 x 2934 mm



STATION GYM

Ref: HER-O3

Dim: 6888 x 4347 x 3729 mm



STATION PARCOURS

Ref: HER-O4

Dim: 5870 x 4656 x 3045 mm

STREET WORKOUT



STATION FIT

Ref: HER-O5

Dim: 7466 x 3163 x 2545 mm



STATION GYMNASTIQUE

Ref: HER-O6

Dim: 9764 x 3159 x 2545 mm



STATION ETOILE

Ref: HER-O7

Dim: 3300 x 3300 x 2540 mm



STATION SUSPENDUE

Ref: HER-O8

Dim: 7500 x 1800 x 2540 mm





STATION MUR

Ref: HER-09

Dim: 7798 x 300 x 2551 mm

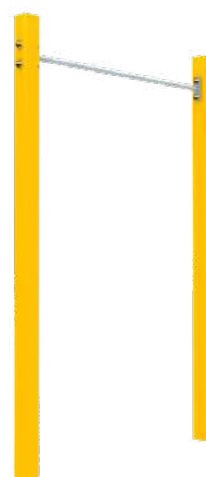

BARRE SIMPLE

Ref: HER-10-1

Dim: 1799 x 300 x 2550 mm



BARRE DOUBLE

Ref: HER-10-2

Dim: 3156 x 300 x 2545 mm



BARRES MIX

Ref: HER-10

Dim: 4797 x 300 x 2550 mm

STREET WORKOUT



STATION SNAKE

Ref: HER-11

Dim: 5000 x 3000 x 2255 mm



STATION INTÉGRÉE

Ref: HER-12

Dim: 7826 x 4545 x 3012 mm



SET ABDOS

Ref: HER-13

Dim: 3844 x 1648 x 2517 mm



MINI BARRES À POMPES

Ref: HER-14

Dim: 580 x 392 x 220 mm



NOUVEAUTÉ



BARRES À POMPES

Ref: HER-14-2

Dim: 590 x 1032 x 315 mm



STEP PLIO 4X

Ref: HER-15

Dim: 2750 x 500 x 550 mm



STATION SOL

Ref: HER-16

Dim: 6095 x 1666 x 1154 mm



BARRES PARALLÈLES DOUBLES

Ref: HER-17

Dim: 4080 x 772 x 1730 mm

STREET WORKOUT



ECHELLE VERTICALE

Ref: HER-18

Dim: 1656 x 170 x 2545 mm



ECHELLE HORIZONTALE

Ref: HER-19

Dim: 2400 x 1800 x 2555 mm

NOUVEAUTÉ

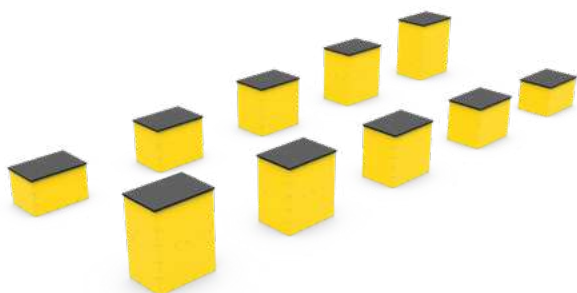

JUMP BOX

Ref: HER-20

Dim: 630 x 450 x 400-800 (10x)

NOUVEAUTÉ

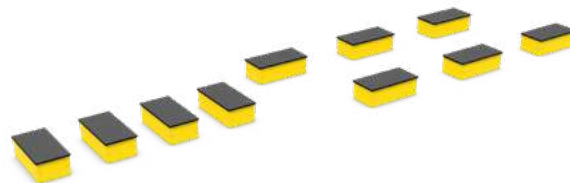

JUMP OBSTACLES

Ref: HER-21

Dim: 300 x 600 x 200 mm (10x)



NOUVEAUTÉ



ETOILE DE RYTHME

Ref: HER-22

Dim: 500x20mm & 200x70mm (4x)

NOUVEAUTÉ

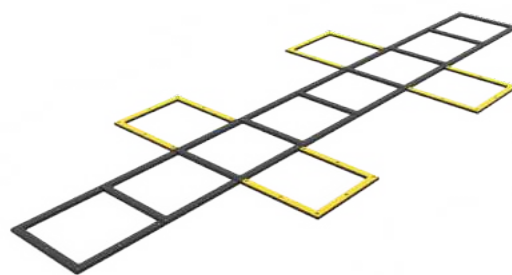

ÉCHELLE DE RYTHME

Ref: HER-23

Dim: 4800 x 1800 x 20 mm

NOUVEAUTÉ



SLALOM

Ref: HER-24

Dim: 200 x 200 x 70 mm (10x)

NOUVEAUTÉ

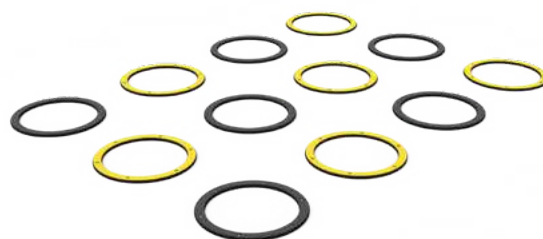

ANNEAUX DE RYTHME

Ref: HER-25

Dim: 500 x 500 x 20 mm (16x)

STREET WORKOUT





Une série adaptée à nos plus jeunes utilisateurs pour pouvoir développer leurs intérêts sportifs.

A series adapted to our youngest users to be able to develop their sports interests.

MINI



MARCHEUR MINI

Ref: MAL-O1

Dim: 1425 x 638 x 1255 mm



TAI CHI MINI

Ref: MAL-O2

Dim: 1113 x 960 x 955 mm



VÉLO MINI

Ref: MAI-O3

Dim: 790 x 280 x 1137 mm



SURFEUR MINI

Ref: MAL-O4

Dim: 1618 x 752 x 1255 mm





Partagez des moments sportifs avec votre chien grâce à nos agrès agility.

Share an active moment with your dog thanks to our agility obstacles!

AGILITY

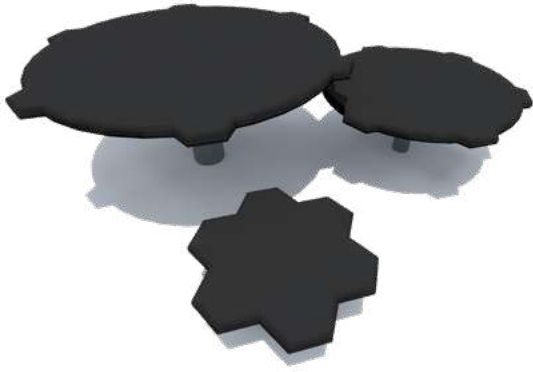

PLATEAU 3

Ref: CN-O1



ANNEAU 1

Ref: CN-O2



TUNNEL 1

Ref: CN-O3

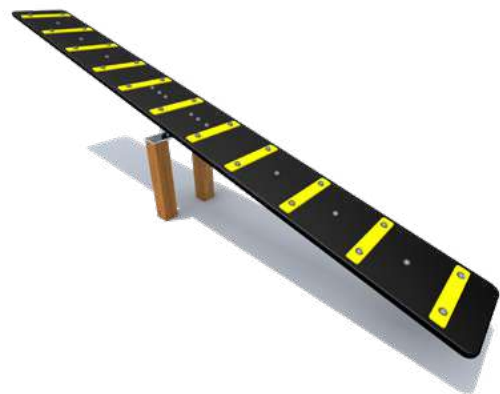

PONT 1

Ref: CN-O4





PYRAMIDE

Ref: CN-O5



PYRAMIDE 2

Ref: CN-O6

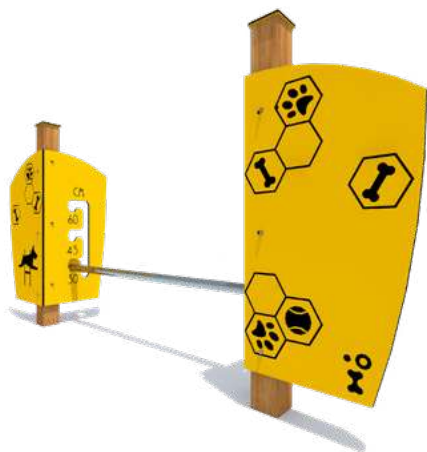

SAUTS

Ref: CN-O7

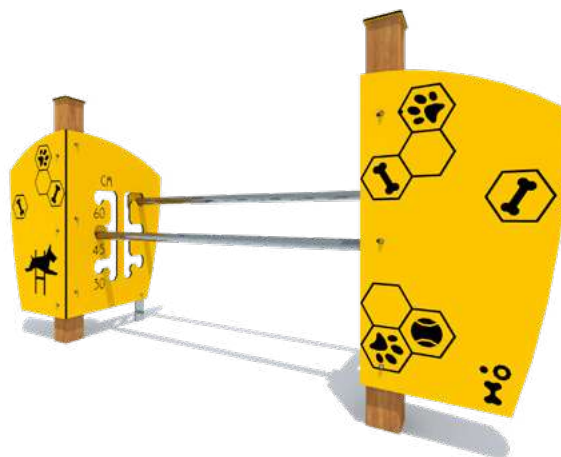

SAUTS DOUBLE

Ref: CN-O8

AGILITY



SAUT PANNEAU

Ref: CN-O9



SLALOM

Ref: CN-IO



PLATEFORME

Ref: CN-II



PLATEAU 1

Ref: CN-I2





PANNEAU D'INFO

Ref: TI-01

Dim: 750 x 50 x 2000 mm



BANC CLASSIQUE

Ref: BNCO1

Dim: 1960 x 640 x 760 mm

Tout ce dont vous pourriez
avoir besoin à côté
de votre parc fitness.

Anything that you
may need next to your
fitness park.

MOBILIER URBAIN



TABLE D'ÉCHEC SIMPLE

Ref: TBL-O1

Dim: 1758 x 1758 x 769 mm



TABLE D'ÉCHEC DOUBLE

Ref: TBL-O2

Dim: 1755 x 1330 x 768 mm



TABLE PING-PONG (VERT)

Ref: PNG (Vert)

Dim: 2740 x 1525 x 760 mm



TABLE PING-PONG (BLEU)

Ref: PNG (bleu)

Dim: 2740 x 1525 x 760 mm



FRANCE:

Herkules Fitness
Île du Platais
78670 Villennes Sur Seine
France

+33 (0)6 95 11 90 09
contact@herkules.fr
www.herkules.fr

POLAND:

Herkules
ul. Karola Szymanowskiego 47A
32 501 Pogorzycze

+48 537 128 667
herkules@silowniezewnetrzne.pl
www.silowniezewnetrzne.pl



HERKULES
FITNESS EN PLEIN AIR

